

K48

TRUCK-MOUNTED CONCRETE BOOM PUMP

Placing boom	B5RZ 48/44
Pumping unit	HP1808ECX HP1606H
Driven by	PTO or gearbox
Chassis	4 axles



Dimensions

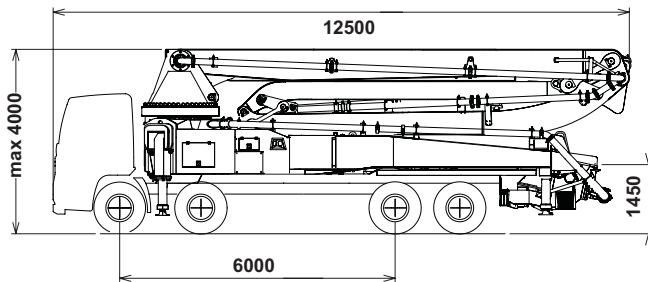

Dimensions varying according to truck assembly

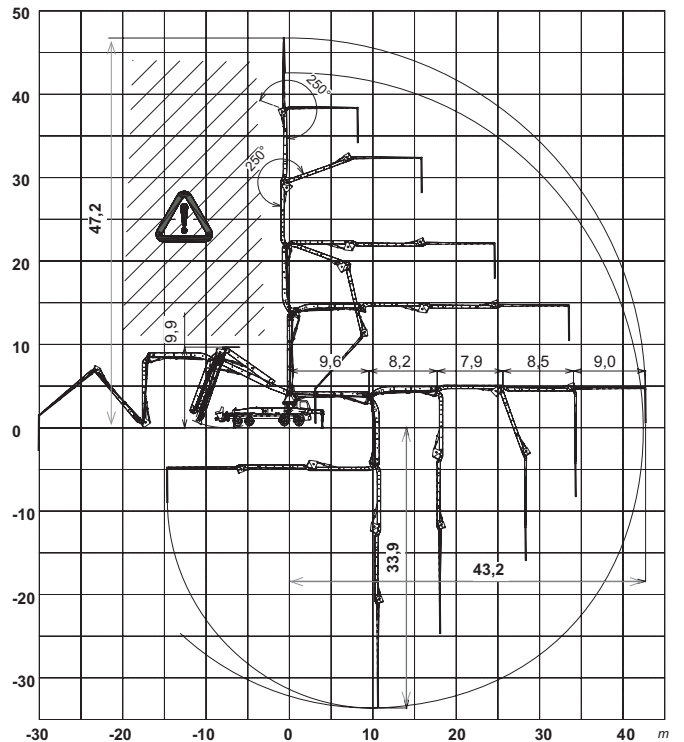
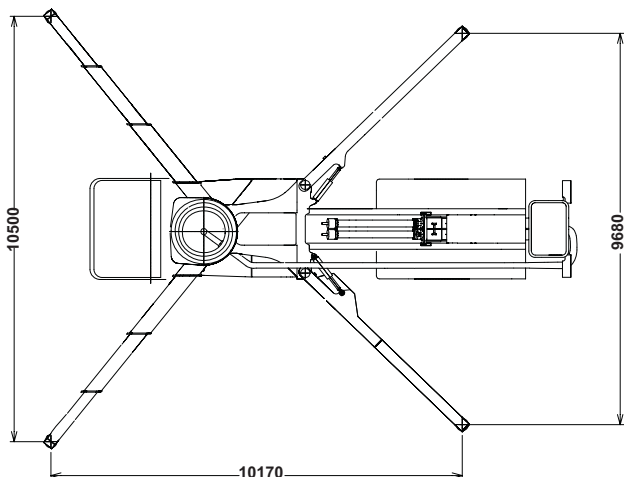

K48

Standard equipment

- Advantageous assembling on standard 4 axle chassis
- Self-supporting frame, torsion free, FEM designed
- Placing boom B5RZ 48/44, 5 sections, pipeline diameter 125 mm, "RZ" folding system
- Fully hydraulic outrigger controls on both sides of the truck
- Front "X style" diagonal outriggers with sequence controlled triple patented telescopic opening and swing-out rear outriggers for a quick and easy set-up
- "Load Sensing" proportional boom control for pumping unit HP-C
- Concrete flow rate regulator
- Safety device on opening inspection hatch
- Pumping unit with closed loop (HP1808ECX) or with open loop (HP1606H)
- Project conforms to Directive Machinery 2006/42/CE
- 2 Proportional radio control Hetriconic 3 joystick. 20 mt cable
- Double thickness concrete pipes, in high resistant steel and insert carbide chrome - CIFA Long Life Pipes
- Emergency control pad for pumping unit HP-C
- Remote controlled electric vibrator placed on the concrete hopper grid
- Centralized lubrication system for pumping unit
- Automatic oil lubrication system for pumping pistons
- Additional manual lubrication system for pumping pistons
- Hard plastic outrigger support plates with relative housing
- Rear light on hopper
- Level readers for stabilization control
- Accessories for cleaning and pipes washing
- Fiber glass hopper covering

Control System with pumping unit HP1808ECX

- Smartronic Silver:
 - integrated color LCD
 - counters
 - pumping unit management
 - diagnostic
 - capsense rear panel

Control System with pumping unit HP1606H

- Easytronic Silver:
 - integrated LCD
 - counters
 - pumping unit management
 - diagnostic

Main options

- Smartronic Gold (Smartronic Silver + ASC Advanced Stability Control)
(Available only with closed loop)
- Easytronic Gold (Easytronic Silver + LSC Light Stability Control)
(Available only with open loop)
- High pressure water pump 28l / 120 bar
- Centralized lubrication system for placing boom
- Separated emergency engine kit for independent control of the concrete pumping unit, boom and water pump
- Double thickness boom straight pipes, in high resistant steel and insert carbide chrome - CIFA LLT Long Life Top
- Proportional radio control with display

TRUCK-MOUNTED CONCRETE BOOM PUMP

Placing boom	B5RZ 48/44
Pumping unit	HP1808ECX HP1606H
Driven by	PTO or gearbox
Chassis	4 axles

Pumping unit technical data

Model		HP1606H	HP1808ECX
Max. theoretical output	<i>m³/h</i>	160	180
Max. pressure on concrete	<i>bar</i>	53	83
Conc. cylinders (diam. x stroke)	<i>mm</i>	230x2100	260x2100
Concrete hopper capacity	<i>l</i>	550	600
Hydraulic circuit		open	closed

Placing boom technical data

Model		B5RZ 48/44
Pipeline diameter	<i>mm</i>	125
Max. vertical reach	<i>m</i>	47,2
Max. horizontal distance (from center of slewing axis)	<i>m</i>	43,2
Min. unfolding height	<i>m</i>	9,9
Section numbers		5
1st section opening angle		90°
2nd section opening angle		180°
3rd section opening angle		180°
4th section opening angle		250°
5th section opening angle		250°
Rotating angle		+/-270°
End hose length	<i>m</i>	4

Technical data and characteristics subject to modifications without notice